

2FV2V Series

Variable Priority Flow Dividers

Priority Type Flow Dividers split a single input flow into a 'Priority' (regulated) flow and a 'By-Pass' (excess) flow which can be returned directly to the oil reservoir or used to power a second system. In many instances this dispenses with the need for another pump to operate a second system.

Specifications

Maximum Pressure:
250 bar (working)

Total flow capacity:
114 lpm

Regulated flow capacity:
See Table 2, ordering codes

Porting:
See Table 3, ordering codes

Material:
Steel components in cast iron body painted black;
aluminium knob (steel knob optional)

Weight:
2.10 to 3.50 Kg

Mounting:
Two bolt - M8 or 5/16"
(Except manifold version which uses 4 bolts)

Relief valve (optional):
Adjustable between 35 - 207 bar
Max. Priority flow - 50 lpm

Check valve (optional):
250 bar working pressure
(Anti-cavitation check valve available)

Symbol

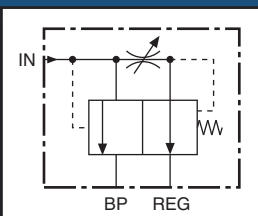

Manufacturers of hydraulic components and test equipment
for the Mobile, Industrial and Agricultural industries



1290 E. Waterford Ave.

Milwaukee, WI 53235

Tel: (414) 769-6400

Fax: (414) 769-6591

www.webster-inst.com

E-mail: sales@webster-inst.com

Features

- Clearly marked single-turn hand dial permits fast visual adjustments to pre-determined 'Priority' flow and fast easy adjustments of 'Priority' circuit to meet varying requirements.
- Pressure compensated permitting both 'Priority' and 'By-Pass' to be used simultaneously at varying pressures without affecting the 'Priority' flow rate.
- All models (except manifold mount) can be supplied with an adjustable pressure relief valve or check valve on 'Priority' flow. Anti-cavitation check valve can be routed between the 'By-Pass' and 'Priority' flows.
- Anti-tamper locknut option available for all models, Contact Sales Office for more information.
- For intermittent reverse flow, needle valve 'pull back' facility available on request.
- Remote control versions available see Hydraulics Catalogue.



2FV2V-BU-USA-2589.pdf 08/10
(Issue 2)

Ordering Codes

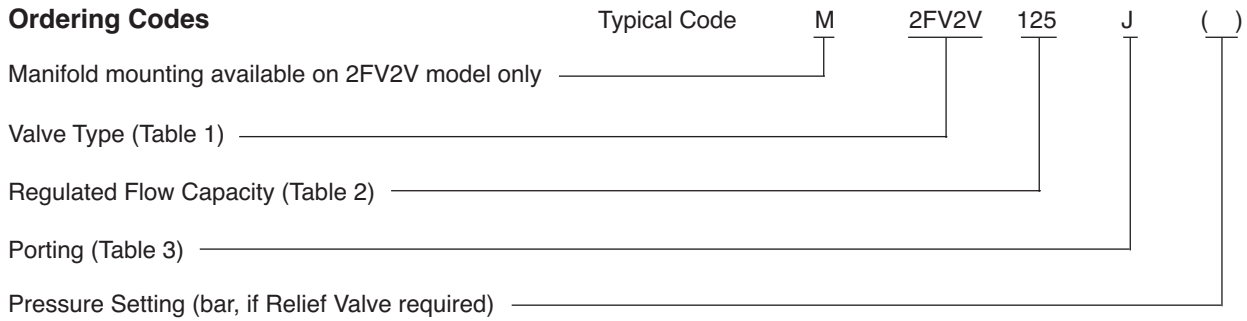

Table 1: Valve Type

Code	Description
2FV2V	No Relief Valve
RV2FV2V	Relief Valve between Priority and By Pass Flow Port
RVXD2FV2V	Externally Drained Relief Valve
CK2FV2V	Check Valve between Priority and Inlet Flow Port
AC2FV2V	Anti-cavitation Check Valve between By-Pass and Priority Flow Port
M2FV2V	Manifold Mounted
PB2FV2V	Pull Back Poppet

Table 2: Regulated Flow

Code	Regulated Flow
030	0 - 11 lpm
050	0 - 19 lpm
080	0 - 30 lpm
125	0 - 47 lpm
200	0 - 76 lpm
250	0 - 95 lpm
300	0 - 114 lpm

Table 3: Porting*

Code	Port Threads Inlet Regulated Flow and Excess Flow	Relief Valve External Drain where fitted
J	3/4" BSPP	1/4" BSPP
A	3/4" NPTF	1/4" NPTF
M	M22 x 1.5, M27 x 2	M14 x 1.5
G	1-1/16" -12UN #12 SAE ORB	9/16" -18UN #6 SAE ORB
H	1/2" BSPP	1/4" BSPP
K	Manifold mounted (custom hole pattern)	N/A

* Other threads available to special order.

Note: M22 only available in flow code 030 to 125
M27 only available in flow code 200 to 300
1/2" BSPP only available in flow code 030 to 125

Typical Pressure Drop 2FV2V Series
(in forward direction)

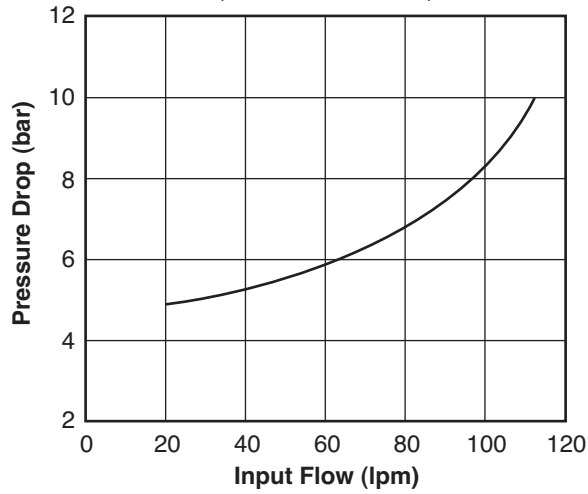

Typical Pressure Drop CK2FV2V Series
(in reverse direction)

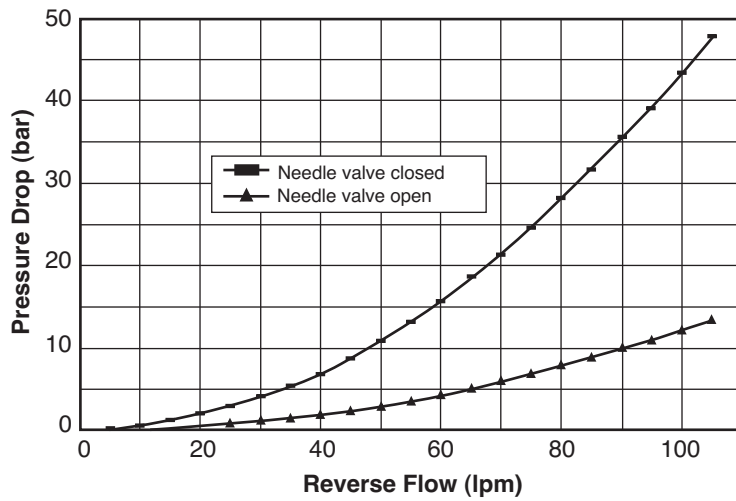

Curve established using hydraulic mineral oil ISO 32 with viscosity of 21 centistokes at 50°C

Typical flow control performance - varying input conditions

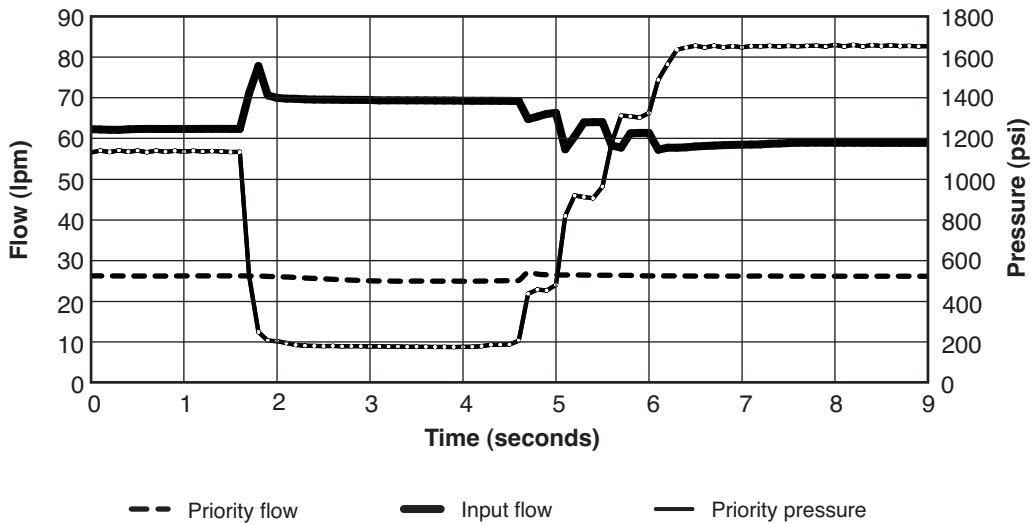

Installation Details

Dimensions in millimetres

(PB) 2FV2V (No Relief Valve)

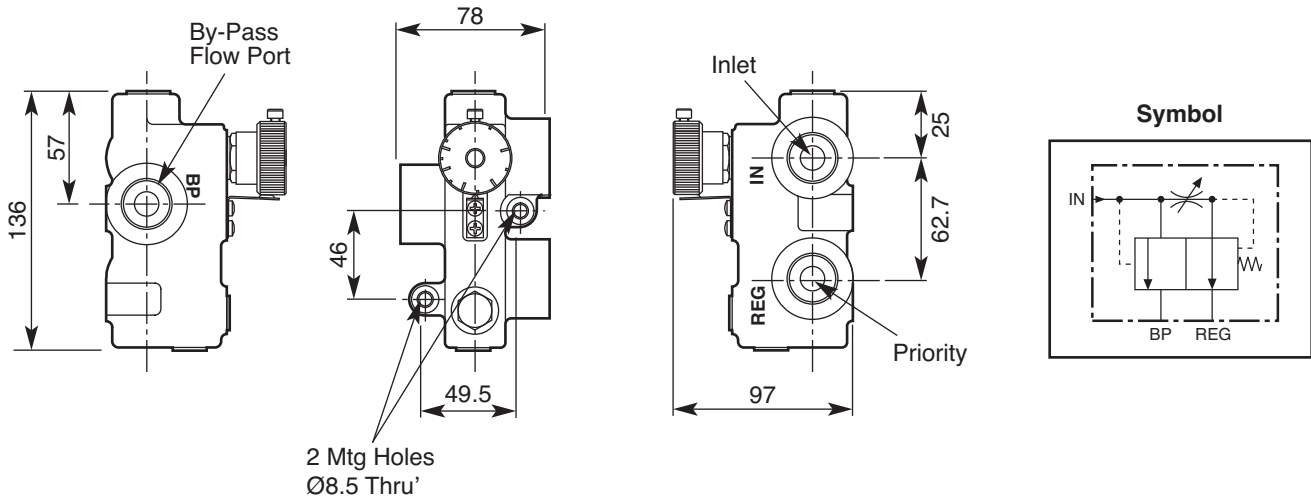

RV2FV2V (Internal Relief Valve between Priority and By-Pass Flow Ports)

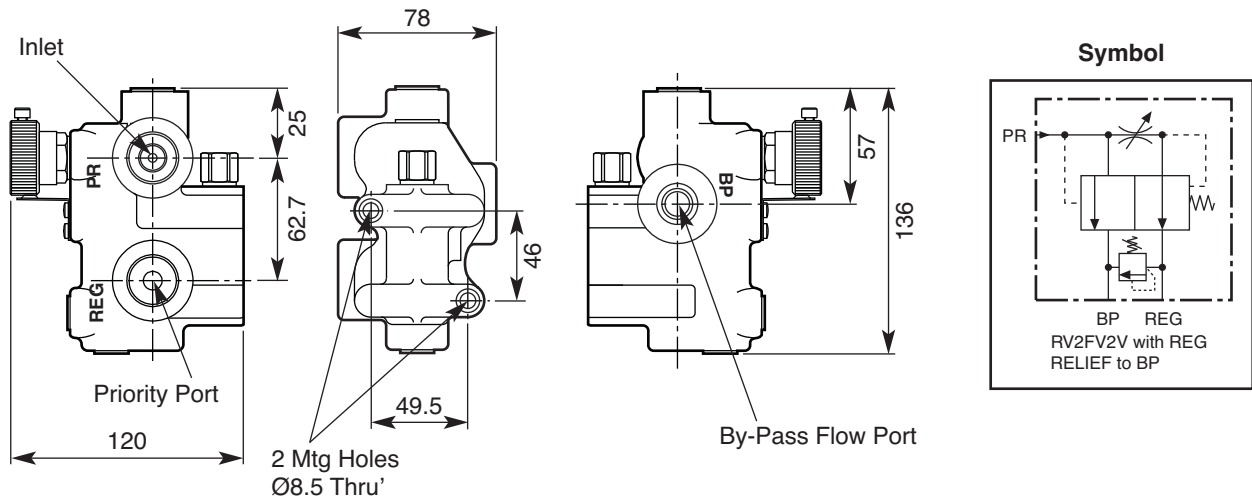

RVXD2FV2V (Externally drained Relief Valve)

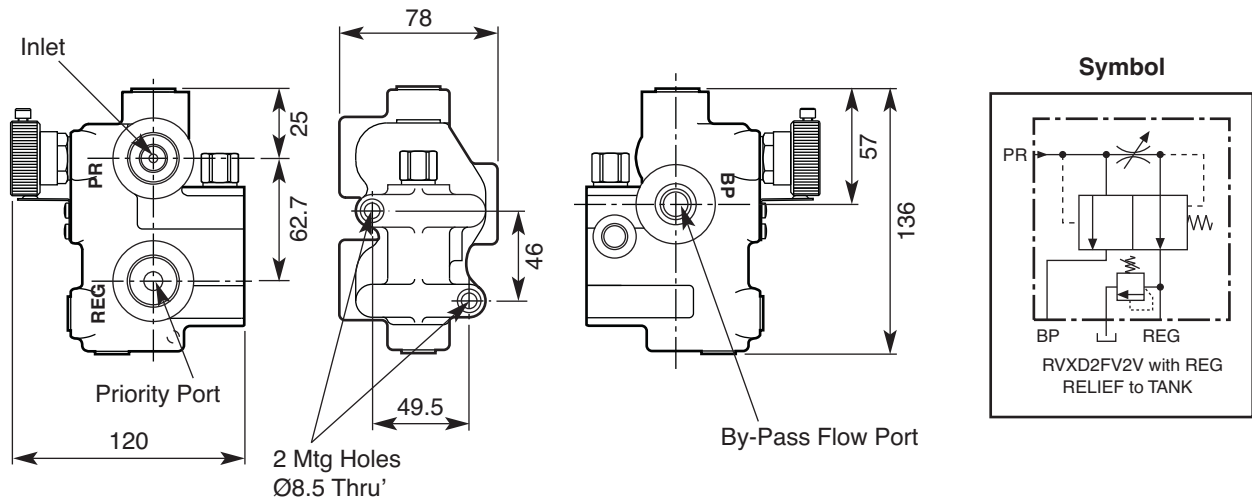

CK2FV2V (Internal Check Valve between the Priority and Inlet Flow Ports)

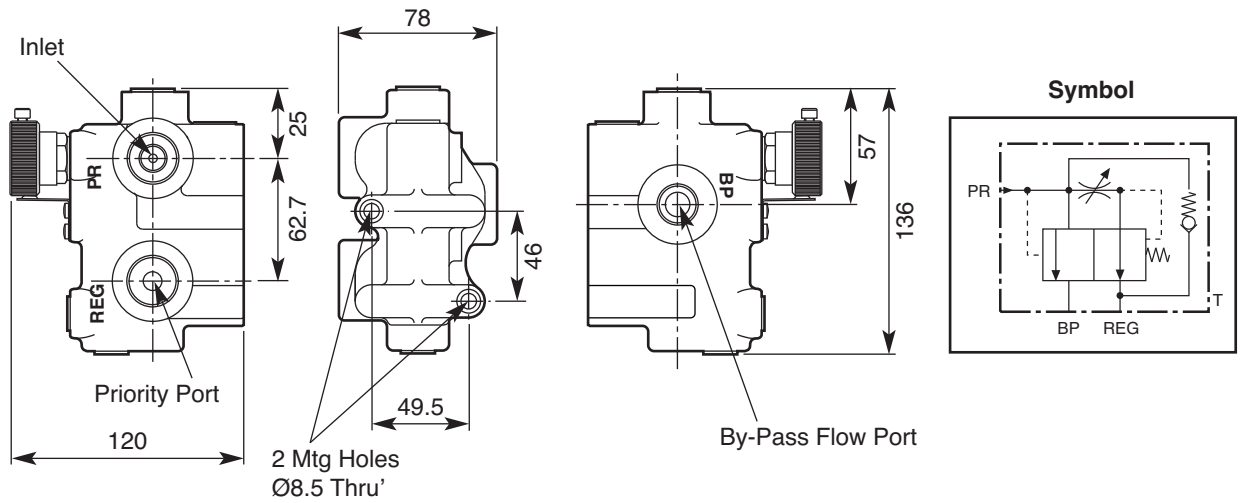

AC2FV2V (Internal Anti-cavitation Check Valve between the By-Pass and Priority Flow Ports)

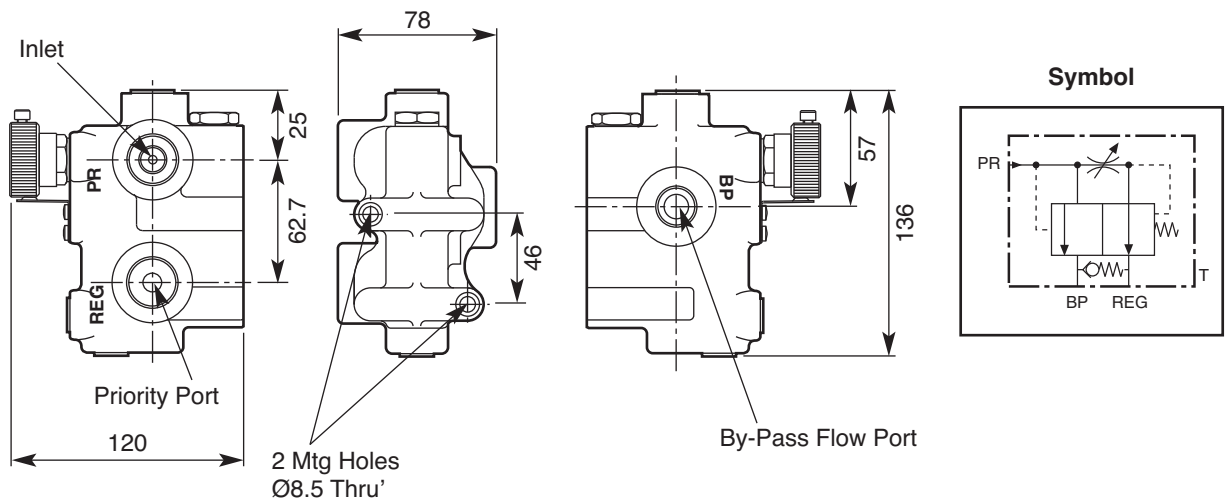

Sectioned View

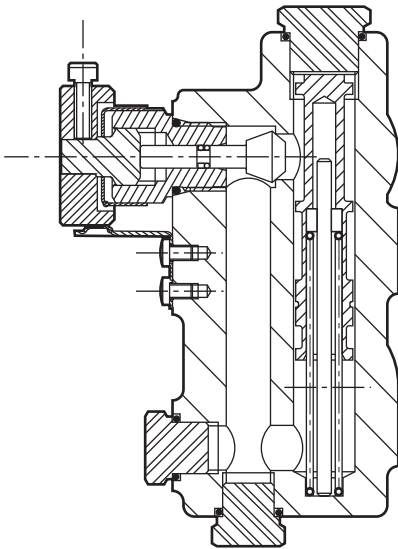

Circuit 1

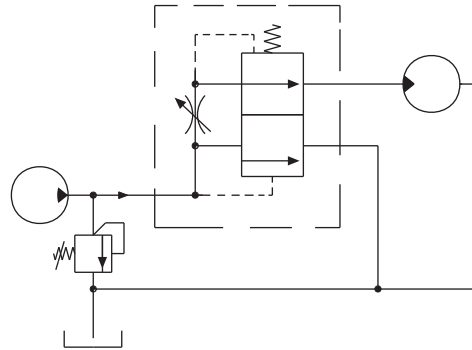

Circuit 2

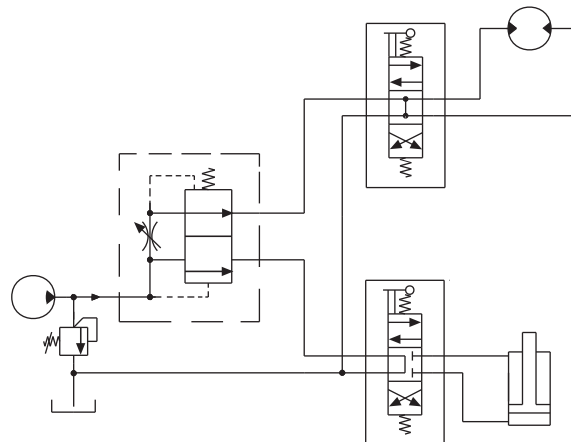

Circuit 3

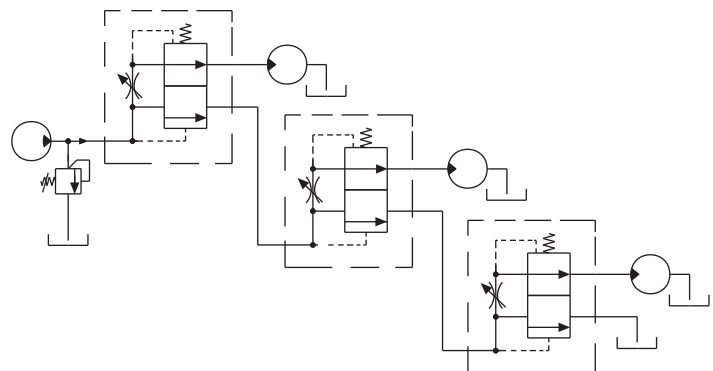

Circuit Suggestions

1 Variable Speed of Hydraulic Motor Drive on Agricultural Tractor

This circuit gives the capability to vary the speed of a hydraulic motor as required. Also, for a given control knob setting, the hydraulic motor speed stays constant regardless of the tractor speed.

2 Two Circuits From a Single Pump

Using only one pump, this circuit gives speed control of the hydraulic motor and powers a hydraulic cylinder. Each function can be used either simultaneously or independently because pressure variations between regulated and By-Pass flows do not effect the flow on the regulated circuit.

3 Multiple Circuits From a Single Pump

Using one pump, this circuit gives independently variable speed drive from three hydraulic motors. Motors can be used simultaneously or independently.



APPROVED