

# 180 Series

## Manual Directional Control Valve

The 180 series of high-pressure hydraulic directional control valves are the ideal solution for starting, stopping, or changing direction of hydraulic actuators on mobile and industrial applications where internal leakage must be kept near zero. The valves utilise a rotary spool with pressure loaded seats. The spool works against optically flat rotors, automatically compensated for valve wear, to assure zero leakage even after more than 500,000 cycles.

The valve is highly customizable to the user's requirements, variations include seven flow patterns, three flow sizes, four porting configurations, straight or offset operating handles, spring centering, detents and different mounting options.

If you can't find a model to suit your application, then contact our sales team to discuss a bespoke design.



Manufacturers of hydraulic components and test equipment  
for the Mobile, Industrial and Agricultural industries



1290 E. Waterford Ave.

Milwaukee, WI 53235

Tel: (414) 769-6400

Fax: (414) 769-6591

www.webster-inst.com

E-mail: sales@webster-inst.com

### Features

- Maximum pressure: Up to 700 bar (10,000 psi)
- Maximum flow: 38 lpm (10 USgpm) See table 3, ordering codes for available flow sizes.
- Porting: BSPP, NPTF, SAE and manifold mount
- Material: Steel components in aluminium body
- Weight: 1.4 kg (3.1 lbs)
- Mounting: Pipe, panel or manifold in any position
- Zero leakage, less than one drop per minute, under test conditions. (See Over).
- Ambient Temperature: -10 to 50°C (14-122°F)
- Fluid Temperature: 20 to 80°C (68-176°F)

### Hydraulic Symbol

Example: 180-E0E

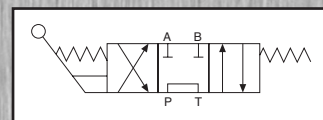

180VALVE-BU-USA-2588.pdf 05/12  
(Issue 7)

## Ordering Codes

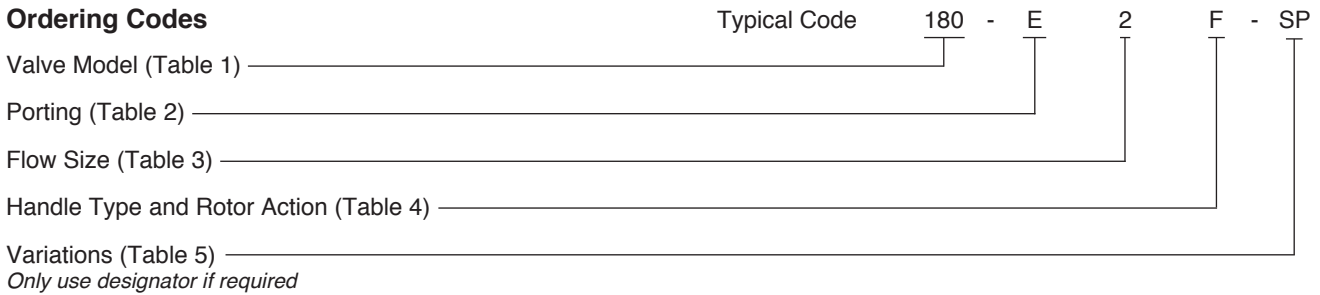

**Table 1: Valve Model**

Code	Symbol
180*	
181*	
182	
183	
184	
185**	
187**	

\* Models 180 & 181 are 3 port configurations. B port plugged. Plug can be moved to A port if required. Models 180 & 181 not available in C or A type porting (Manifold mount).

\*\* Models 185 and 187 available in 1 and 2 flow sizes only

**Table 2: Porting**

Code	Port size
L	9/16" -18UN #6 SAE ORB
E	3/8" NPTF
T	3/8" BSPP
C	Manifold Mount Type 1 Installation (see page 3) - counter bored to take BS1806 (AS568 A) 014 O ring
A	Manifold Mount Type 2 Installation (see page 3) - counter bored to take BS1806 (AS568 A) 014 O ring

*Note - All NPTF threads are to ANSI B1.20.3 -1976 Class 1. As stated in the standard it is recommended that "sealing is accomplished by the means of a sealant applied to the thread". NPT fittings may also be used to connect to NPTF ports (also with a sealant applied to the thread)*

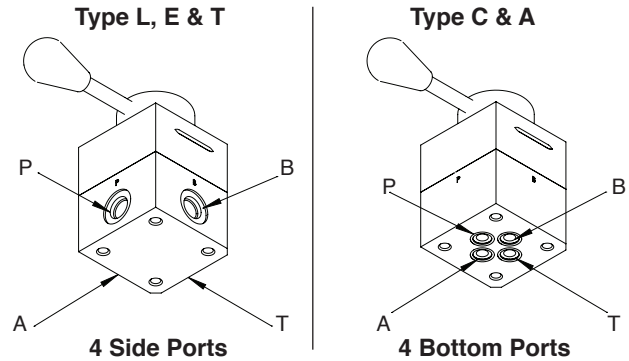

**Table 3: Flow Size**

Code	Maximum flow	Maximum pressure**	Pressure drop curve	Interflow*
0	15 lpm (4 US gpm)	700 bar (10,000 psi)	A	None
1	26.5 lpm (7 US gpm)	350 bar (5,000 psi)	B	Low
2	38 lpm (10 US gpm)	207 bar (3,000 psi)	C	Med

\* Interflow flow measure in half way position under test conditions.

\*\* Maximum pressure on all spring centred valve 3,000 psi regardless of flow size.

**Table 4: Handle Type & Rotor Action**

Code	Handle Type	Action
D	Straight	Detented Action
E	Straight	Spring Centred Action
F	Offset 18°	Detented Action + Panel Mount
G	Offset 18°	Spring Centred Action + Panel Mount

**Table 5: Variations (Only use if required)**

Code	Function
SP	Customer Special
A	Valves to be used in Series (Tank line pressurised, NPTF drain in Cover.)

**Test Conditions: Using ISO32 Oil at 45°C, 3000 psi.**

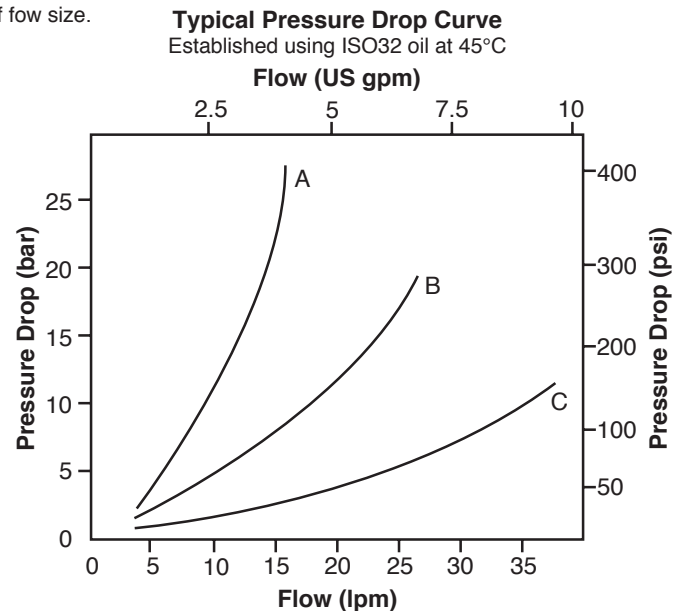

# Installation Details

Dimensions in millimetres (Inches)

## Manifold Mount Type 1 Installation (C Porting)

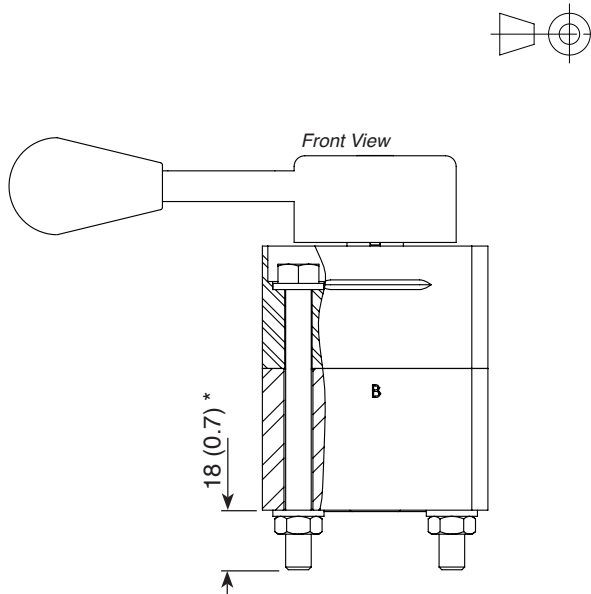

4 x 5/16"-18UNC, through bolts \*

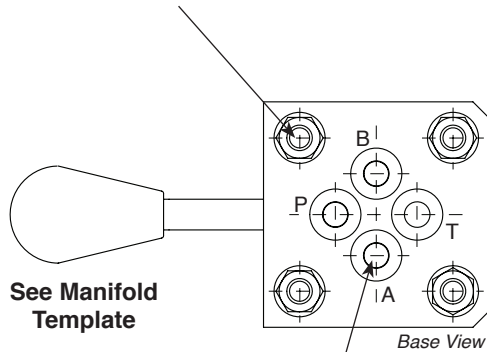

4 x C/bores for O14 type O'rings (BS1806).  
 $\varnothing 15.9 (0.63) \times 1.26 (0.05)$  deep.

## Manifold Mount Type 2 Installation (A Porting)

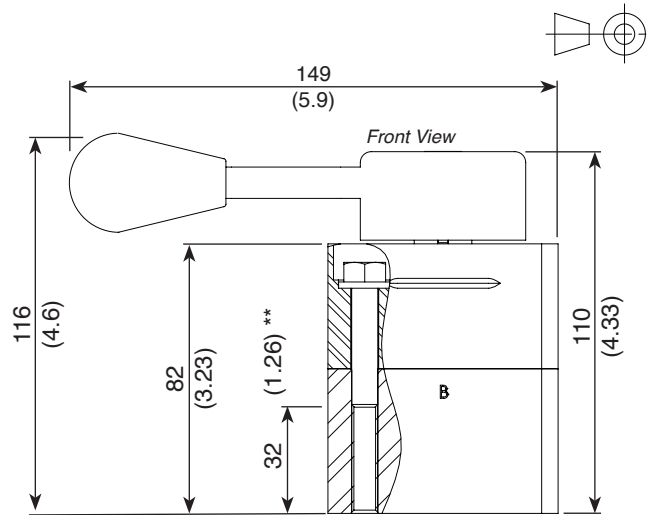

4 Holes 5/16"-18 UNC-2B \*\*

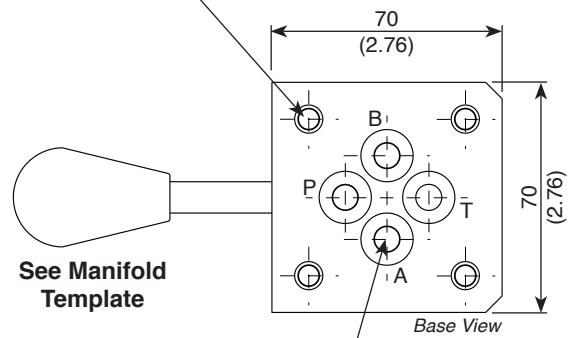

4 x C/bores for O14 type O'rings (BS1806).  
 $\varnothing 15.9 (0.63) \times 1.26 (0.05)$  deep.

## Manifold Template

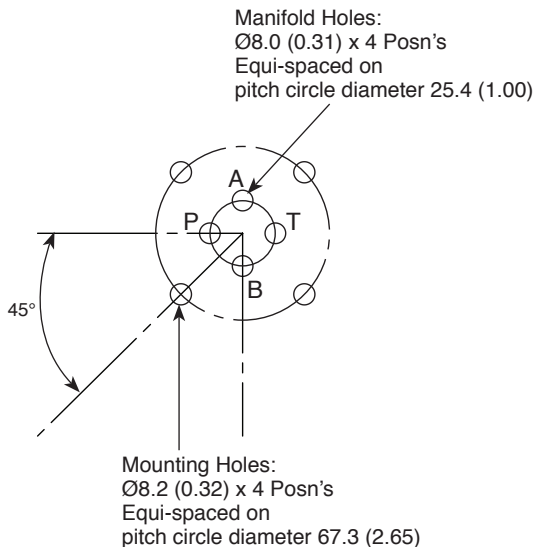

## \* Manifold Mount Type 1 Installation (C Porting)

The valve is pre-assembled for test using 4 off 5/16"-18UNC through bolts, nuts, & washers. Some dis-assembly is required for installation, during which care should be taken not to allow debris to enter the valve.

To ensure correct operation, the valve re-assembly tightening torque to be used is 23Nm (17Lbft).

## \*\* Manifold Mount Type 2 Installation (A Porting)

The valve is mounted using 4 off 5/16"-18UNC-2B x 32mm (1.26) deep tapped holes which are provided on the underside.

Fixing bolts not included.

In the case of Panel mount with type 2 Manifold installation, the UNC holes will be only 25mm (1.0) deep.

### Side Porting: Type E, L & T

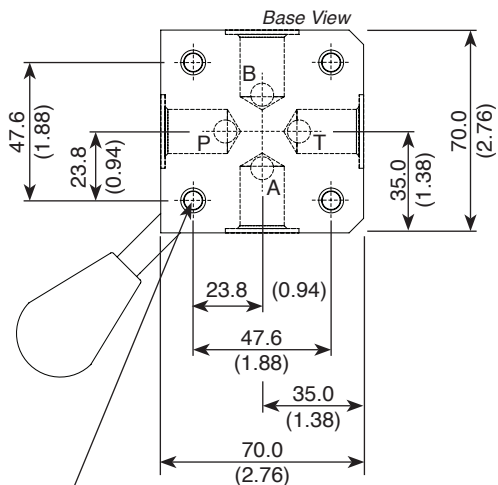
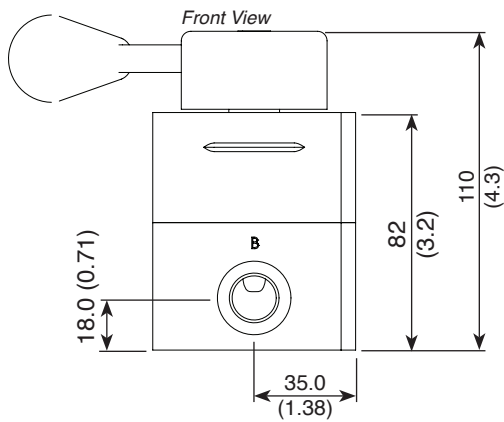
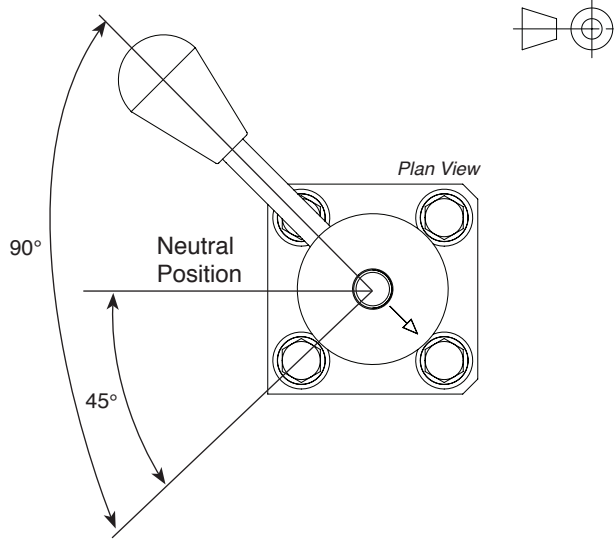

4 Holes  
5/16"-18 UNC-2B x 32 (1.26) Deep

### Panel Mount

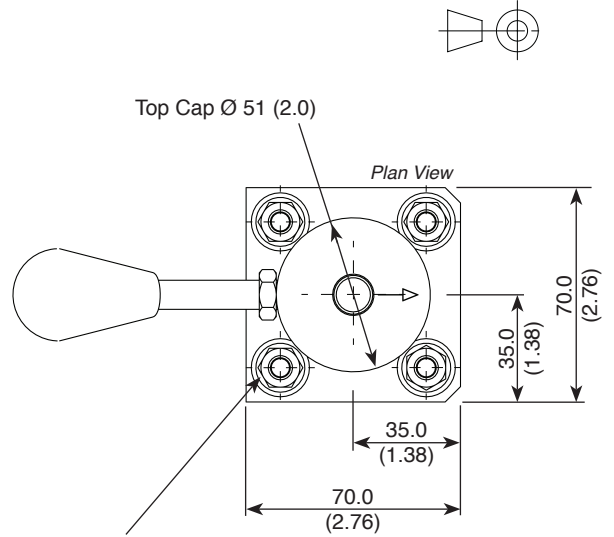

5/16"-18UNC x 7.9 (0.31) deep.  
4 Mounting holes.

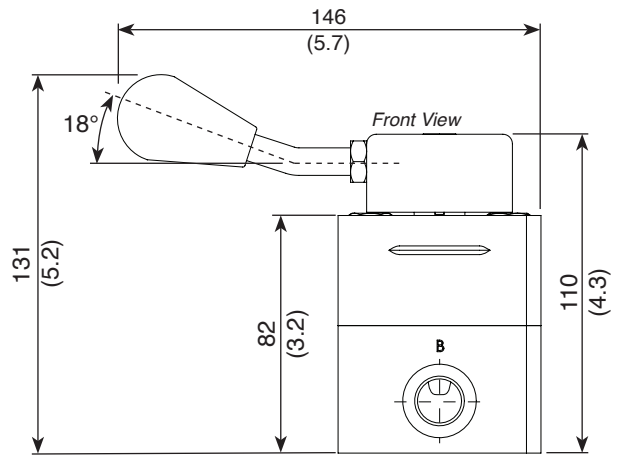

### Panel Mount Template

Mounting Holes:  
 $\varnothing$ 8.2 (0.32) x 4 Posn's  
Equi-spaced on  
pitch circle diameter 67.3 (2.65)

