

# HV Series Load valves

Up to

- 800 lpm, 210 US gpm
- 420 bar, 6,000 psi

The HV series of loading valve gives smooth progressive pressure control in both flow directions allowing components such as cylinders or motors to be tested without re-plumbing the test connections.

The valve features the exclusive INTERPASS™ safety disc system which protects the operator, components and the environment by preventing unwanted external oil loss. In the event of overpressure the discs rupture and oil bypasses the valve internally at low pressure.

The valve features a gauge port which is ported to the inlet (in the forward direction). Combined with our flow meters or portable testers, the HV series loading valve makes testing hydraulic components and circuits on a wide range of agricultural, industrial and mobile equipment fast, efficient and safe.

Please note that the HV Series are designed for loading a system and are not suitable as a shut-off valve to hold a static load.



Manufacturers of hydraulic components and test equipment  
for the Mobile, Industrial and Agricultural industries



1290 E. Waterford Ave.

Milwaukee, WI 53235

Tel: (414) 769-6400

Fax: (414) 769-6591

www.webster-inst.com

E-mail: sales@webster-inst.com

## Features

- **FLOW:** Up to 800 lpm, 210 US gpm
- **PRESSURE:** Up to 420 bar, 6000 psi
- **BI-DIRECTIONAL** loading
- **INTERPASS™** internal safety protection system with replaceable burst discs
- **SMOOTH** progressive pressure control
- **HIGH** tensile aluminium body rated at 6000 psi
- **EASY** to retro-fit



HV100LV-BU-USA-1668.pdf 02/10  
(Issue 2)

## Specification

Model number	Flow range	Port one	Port two
HV100-B-N-6	100 lpm	3/4 BSPP**	1/2 BSPP
HV200-B-N-6	200 lpm	1-1/16" -12UN #12 SAE ORB	3/4 BSPP
HV100-S-N-6	25 US gpm	1/2" NPTF	3/4" -16UN #8 SAE ORB
HV200-S-N-6	50 US gpm	1-1/16" -12UN #12 SAE ORB	1-1/16" -12UN #12 SAE ORB
HV400-S-N-6	100 US gpm (400 lpm)	1-5/16" -12UN #16 SAE ORB	1-5/16" -12UN #16 SAE ORB
HV800-S-N-6	210 US gpm*(800 lpm)	1-7/8" -12UN #24 SAE ORB	1-7/8" -12UN #24 SAE ORB

\* Pressure control is limited below 86 lpm (23 US gpm) to: Max pressure (bar) = 5 times the flow (lpm) +30

\*\*Supplied with an adaptor to provide stated port

## Dimensions

Model number	A	B	C	D	Weight
HV100-B-N-6	108 mm	122 mm	50 mm	62 mm	1.3 kg (2.8 lb)
HV200-B-N-6	121 mm	130 mm	50 mm	75 mm	1.5 Kg (3.3 lb)
HV100-S-N-6	108 mm	122 mm	50 mm	62 mm	1.3 kg (2.8 lb)
HV200-S-N-6	121 mm	130 mm	50 mm	75 mm	1.5 Kg (3.3 lb)
HV400-S-N-6	95 mm	180 mm	50 mm	100 mm	2 Kg (4.4 lb)
HV800-S-N-6	114 mm	208 mm	76 mm	125 mm	2 Kg (4.4 lb)

## Functional specification

**Ambient temperature:** 5 to 40°C (59 to 104°F)

**Fluid type:** hydraulic oil

**Fluid temperature:** 0 to 120°C (32 to 250°F)

**Max pressure:** 420 bar (6000 psi)

**Gauge port:** 1/4"NPT

## Installation

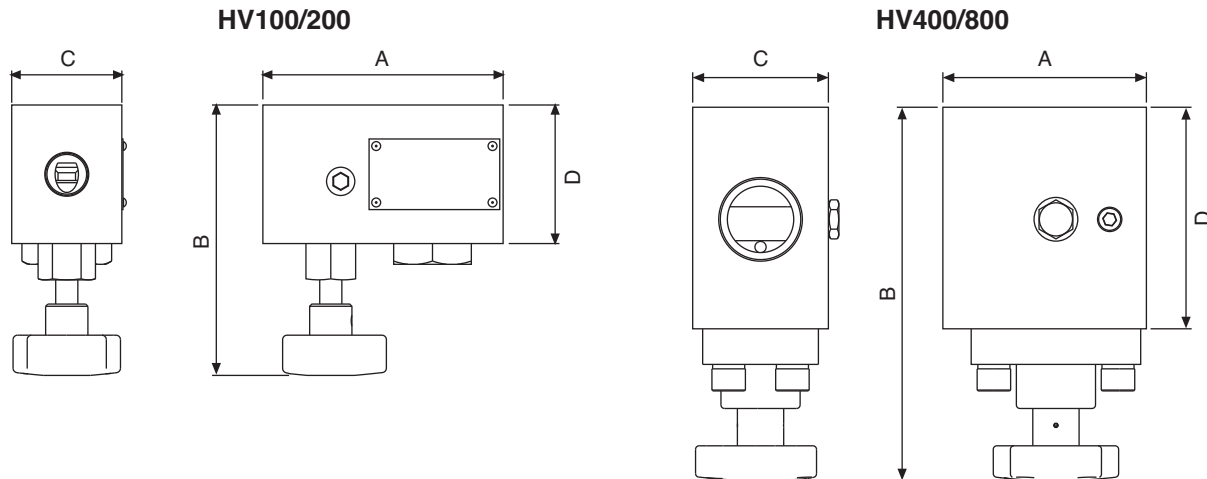

## Construction material

**Main body:** Aluminium 2011T6

**Internal parts:** Steel (Grades 817M40, 722M24, 230M07)

**Seals:** Viton (other available on request)

**Each valve is supplied with 4 spare burst discs**

## Accessories / options

**CT:** range of turbine flow blocks - from 1 to 1500 lpm (0.25 - 400 US gpm) see separate bulletin

**Pressure gauges**

**Test points**

**Replacement burst discs:** 6000, 5000, 4000 and 3,000 psi

**HV1500 kit**

Please contact sales for full details or advice.