

CT Series

Turbine flow meters with conditioned output

Up to

- 1500 lpm, 400 US gpm
- 480 bar, 7000 psi

Output Options

- 4 - 20 mA, 0 - 5 V

The CT turbine flow meter with conditioned output provides a complete solution to the flow measurement of hydraulic systems on test stands, machine tools and other fixed or mobile applications. The flow meter can be installed anywhere in the hydraulic circuit for production testing, commissioning, development testing and analysis of control systems. The compact design allows the CT series flow meters to be installed where space is limited.

The CT turbine flow meter has a built-in micro-controller that conditions the signal from the flow meter to provide an accurate analogue output. This enables you to connect the flowmeter directly into your digital display, PLC or custom DAQ system without having to worry about complex calibration factors or lookup tables. Two versions are available offering 4 - 20 mA current loop or 0 - 5 V.

The CT flowmeter is the ideal tool for monitoring the performance of pumps, motors, valves and hydrostatic transmissions.

CT mA model shown



Manufacturers of hydraulic components and test equipment
for the Mobile, Industrial and Agricultural industries



1290 E. Waterford Ave.

Milwaukee, WI 53235

Tel: (414) 769-6400

Fax: (414) 769-6591

www.webster-inst.com

E-mail: sales@webster-inst.com

Features

- **FLOW:** 1 - 1500 lpm, 0.25 - 400 US gpm
- **PRESSURE:** Up to 480 bar, 7000 psi
- **OUTPUT OPTIONS:** 4 - 20 mA or 0 - 5 V
- **BI-DIRECTIONAL** operation
- **FLUIDS:** Wide range of hydraulic oil, lubrication oils, and fuels
- **CALIBRATION:** 21 cSt as standard. Special calibration possible
- **COMPREHENSIVE** range of accessories available including pressure transducers, temperature sensors panel meters and cables. See MPT, TP125 and DP130 bulletin for details or consult sales office



CT-BU-USA-2480.pdf
(Issue 8)

01/12

Specifications

Model Number	Outputs available	Main ports	Top ports*	Flow range	Max. pressure
CT15-**-B-B-6	5V, mA	1/2" BSPP	1/4" BSPP	1 - 15 lpm	420 bar
CT15-**-S-S-6	5V, mA	3/4" -16UN #8 SAE ORB	7/16" -20UN #4 SAE ORB	0.25 - 4 US gpm	6000 psi
CT60-**-B-B-6	5V, mA	3/4" BSPP	1/4" BSPP	3 - 60 lpm	420 bar
CT60-**-S-S-6	5V, mA	1-1/16" -12UN #12 SAE ORB	7/16" -20UN #4 SAE ORB	0.8 - 16 US gpm	6000 psi
CT150-**-B-B-6	5V, mA	3/4" BSPP	1/4" BSPP	5 - 150 lpm	420 bar
CT150-**-S-S-6	5V, mA	1-1/16" -12UN #12 SAE ORB	7/16" -20UN #4 SAE ORB	1.3 - 40 US gpm	6000 psi
CT300-**-B-B-6	5V, mA	1" BSPP	1/4" BSPP	8 - 300 lpm	420 bar
CT300-**-S-S-6	5V, mA	1-5/16" -12UN #16 SAE ORB	7/16" -20UN #4 SAE ORB	2 - 80 US gpm	6000 psi
CT400-**-B-B-6	5V, mA	1" BSPP	1/4" BSPP	10 - 400 lpm	420 bar
CT400-**-S-S-6	5V, mA	1-5/16" -12UN #16 SAE ORB	7/16" -20UN #4 SAE ORB	2.5 - 100 US gpm	6000 psi
CT600-**-B-B-5	5V, mA	1-1/4" BSPP	1/4" BSPP	15 - 600 lpm	350 bar
CT600-**-F-S-3	5V, mA	1-1/2" #24 SAE Code 61 4-bolt flange	7/16" -20UN #4 SAE ORB	5 - 160 US gpm	3000 psi
CT600-**-S-S-5	5V, mA	1-5/8" -12UN #20 SAE ORB	7/16" -20UN #4 SAE ORB	4 - 160 US gpm	5000 psi
CT800-**-S-B-7	5V, mA	1-7/8" -12UN #24 SAE ORB	1/4" BSPP	20 - 800 lpm	480 bar
CT800-**-S-S-7	5V, mA	1-7/8" -12UN #24 SAE ORB	7/16" -20UN #4 SAE ORB	5 - 210 US gpm	7000 psi
CT800-**-F-B-3	5V, mA	1-1/2" #24 SAE Code 61 4-bolt flange	1/4" BSPP	20 - 800 lpm	210 bar
CT800-**-F-S-3	5V, mA	1-1/2" #24 SAE Code 61 4-bolt flange	7/16" -20UN #4 SAE ORB	5 - 210 US gpm	3000 psi
CT1500-**-F-S-6	5V, mA	1-1/2" #24 SAE Code 62 4-bolt flange	7/16" -20UN #4 SAE ORB	12.5 - 400 US gpm (50 - 1500 lpm)	420 bar

Replace ** with SR, mA or 5V to give complete model number. *CT 15 has one of the specified top ports.

Functional specification

Ambient temperature: 5 to 40 °C (41 - 104 °F)
Fluid type: Oils, fuels, water glycol, water oil emulsions
Fluid temperature: 5 to 90 °C (41 - 194 °F) continuous use.
Accuracy: 15 to 100% of range - 1% of indicated reading
 Below 15% fixed accuracy of 1% of 15% of full scale (CT15 is 1% of full scale)
Repeatability: Better than ± 0.2%
Response Time: 50 ms + 1 period

Electrical specification

Supply voltage (VS): mA & 5V = 12 - 32 VDC
Current output: 4 - 20 mA, 3 wire loop, max loop resistance = (VS x 50) - 200 ohms
Voltage output: 0 - 5 VDC, current consumption = 10 mA, minimum load 20K ohms

Construction material

Flow body: 600/800/1500 High tensile Aluminium 2014A T6
 15/60/150/300/400 High tensile Aluminium 2011 T6
Internal parts: Aluminium, Steel, Stainless Steel.
Transducer: Body and nut -steel 212A42 electrodeless nickel plated, Housing and Lid - Aluminium 2011 T3
Seals: Viton seals as standard EPDM are available - please consult sales office.

Operation

As fluid is passed through the flow block it rotates a precision turbine. The flow straighteners and turbine design minimise the effects of turbulence and swirl. The turbine blades are detected by the magnetic reluctance transducer which produces a pulse output. The flow block has ports for pressure or temperature sensors which can be supplied as an option.

Reverse Flow

The flow block is capable of measuring flow in either direction.

Calibration

All units are calibrated with 21 cSt oil as standard. Calibration certificates are available on request - this is a chargeable option. Production calibration of CT1500 lpm turbine is confirmed by testing over the range of 50 to 750 lpm and by design only above 750lpm. Other calibration on request - please consult the sales office.

Installation

The flow block has built-in flow straighteners so the normal recommended length of 10 Ø of straight tube can be reduced to 8 Ø where space is limited. Inlet and outlet connections should always be of a similar bore size to that of the flow block to prevent venturi or constriction effects. The range of flow meters can be used for intermittent or continuous testing of

flow in either direction. The flow block can be mounted in any orientation. For heavy duty applications where the flow block will be used constantly with continuous pressure spikes please contact sales to discuss your application.

Filtration

It is recommended that a 25-micron (10 micron for CT15) filter is installed in the circuit prior to the flow block.

Top ports

Most flow meters have two additional ports (see table for configuration) in the top face of the flow meter to enable the user to connect both a temperature and pressure sensor. The CT15 has one top port. All flow blocks come with one M16 x 2 test point fitted as standard.

Ordering

To order an CT flow meter please quote the model number from the table above. eg: CT15-B-B-6. All CT flow blocks (excluding CT15) can have both a temperature sensor and pressure transducer connected simultaneously.

Pressure Drop Chart

Hydraulic Oil Viscosity 21 Centistokes

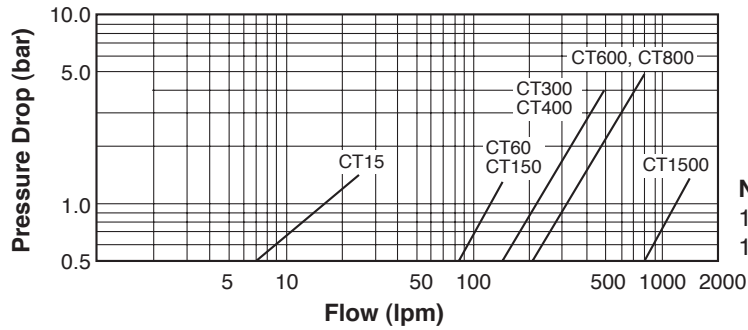

Note:
 1 UK gallon = 4.546 litres
 1 US gallon = 3.785 litres

Connection Details

5V

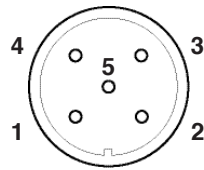

Pins

- 1 = +In
- 2 = N/C
- 3 = 0 - 5V out
- 4 = N/C
- 5 = GND

4 - 20 mA

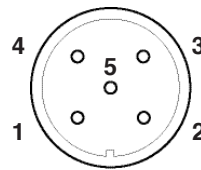

Pins

- 1 = +In
- 2 = N/C
- 3 = 4 - 20mA out
- 4 = N/C
- 5 = GND

NB. N/C - Do not connect

Connecting cable (5m)	FT10228-05
Extension cable (5m)	FT10229-05
Connector (M12x1 5 pin)	FT9880

Dimensions in mm (inches)

Model No	A	B	C	D	E	Weight kg (lbs)
CT15	37 (1-1/2")	136 (5-3/8")	37 (1-1/2")	123 (5")	69.5 (2-3/4")	0.7 (1.5)
CT60	62 (2-1/2")	190 (7-1/2")	50 (2")	136 (5-3/8")	103 (4")	1.6 (3.5)
CT150	62 (2-1/2")	190 (7-1/2")	50 (2")	136 (5-3/8")	103 (4")	1.6 (3.5)
CT300	62 (2-1/2")	190 (7-1/2")	50 (2")	140 (5-1/2")	103 (4")	1.7 (3.7)
CT400	62 (2-1/2")	190 (7-1/2")	50 (2")	140 (5-1/2")	103 (4")	1.7 (3.7)
CT600	62 (2-1/2")	212 (8-3/8")	75 (3")	156 (6")	127 (5")	2.7 (6)
CT600-**-F-**-*	100 (4")	212 (8-3/8")	75 (3")	160 (6-1/4")	126 (5")	5.0 (11)
CT800	100 (4")	212 (8-3/8")	75 (3")	160 (6-1/4")	126 (5")	5.0 (11)
CT1500	140 (5-1/2")	260 (10-1/4")	100 (4")	176 (7")*	130 (5-1/8")	10.0 (22)

* CT1500 includes 4 feet on base, add 20 mm (3/4") to D for full height.
 CT1500 is fitted with carry handles - not shown on diagram.

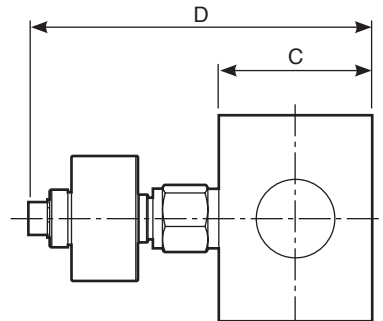
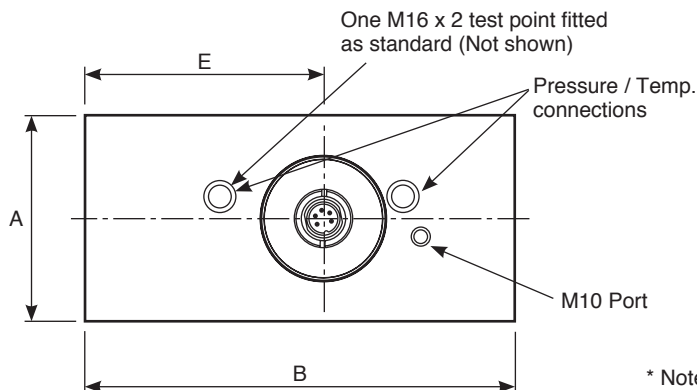

* Note. CT 15 has also one Pressure / Temp connection

Turbine Flow Meters

Accuracy

The accuracy is better described as the uncertainty of the flow reading compared to a known reference. Every flow measurement has an error associated with it, caused by the combination of a large number of factors that affect the operation of the flow meter, these include bearing friction, temperature, viscosity, magnetic drag and the signal strength to name but a few.

All our flow meters are calibrated at 10 points over the flow range and its performance measured against a flow reference that is traceable to International standards. Accuracy is typically quoted in one of two ways: as a percentage of full scale (the maximum calibrated flow) or as a percentage of the indicated reading (the actual flow).

Full scale (FS) or full scale deflection (FSD)

A term that was originally used for analogue displays where a needle pointed to a number on a scale, hence FSD. The flow accuracy is a fixed amount regardless of the actual flow you are measuring. For example 1% FS for a flow meter with a maximum calibrated flow of 400 lpm is ± 4 lpm whether you are measuring 40 lpm, 200 lpm or 400 lpm (see graph below). If you need to measure flows of 40 and 400 lpm with same flow meter then it is important to check the allowable error at all flows.

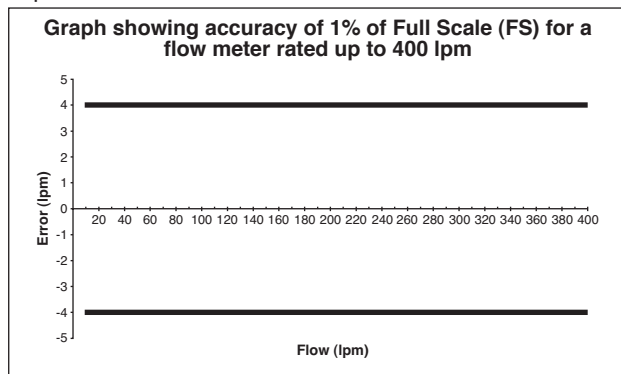

Indicated reading (IR)

Accuracy is quoted as a percentage of the actual value measured. So if the accuracy of a 400 lpm flow meter is 1% IR then the error at 400 lpm is ± 4 lpm. As the actual flow measured reduces, so does the error in lpm. When measuring a flow of 60 lpm with an accuracy of 1% IR, the possible error is ± 0.6 lpm. At very low flows, the possible errors are no longer proportional to the flow rate, but actually a fixed amount in lpm (see graph below). For example if the accuracy is quoted as 1% IR (>60 lpm) for a flow meter with the range 10 - 400 lpm, then the accuracy is 1% of the actual flow in the range 60 to 400 lpm and a fixed flow error in the range 10 to <60 lpm.

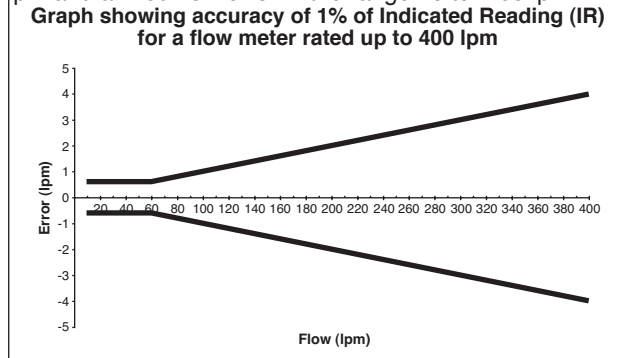

Repeatability

The repeatability is the variation in the performance of the flow meter when used under the same conditions. Our range of flow meters has excellent repeatability of better than $\pm 0.2\%$. This is just as important as the accuracy since in many applications the flow readings from the same flow meter will be compared at regular intervals to look for any change in performance of the system.

Flow range (Turndown ratio)

A turbine flow meter has a minimum and a maximum calibrated flow which together describe the range of flows that can be accurately measured. Through the addition of signal conditioning either mounted on the flow meter or built into the readout, the flow range of our flow meters has been extended considerably compared to other models on the market; the ratio of the maximum to the minimum calibrated flow (turndown ratio) is between 15 and 40 across all models. Particular effort has been made to extend the flow range by calibrating down to lower flows enabling one flow meter to be used where two may have been required in the past. This makes the flow meter both a more economical and easier to install solution.

Fluid viscosity

The performance of a turbine flow meter can be affected by the viscosity of the fluid measured. Our turbine flow meters are calibrated at between 18 and 26 cSt as standard (a mean viscosity of 21 cSt), which is the typical kinematic viscosity for a hydraulic fluid operating at 50 °C. The kinematic viscosity of all hydraulic fluids is related to the fluid temperature and the table below shows the affect of temperature on the kinematic viscosity of a range of typical grades of hydraulic oil.

The shaded area of the table shows the range of viscosities that can be measured by a flow meter with standard calibration with minimal effect on the accuracy (less than $\pm 1\%$ FS).

Flow meters can be specially calibrated at a different viscosity to the standard or we can advise on the expected error when the flow meter is used at other viscosities, please contact sales for further information.

Table showing kinematic viscosity (cSt) of different mineral oils at specific temperatures

Temp °C	ISO15	ISO22	ISO32	ISO37	ISO46	ISO68
0	85.9	165.6	309.3	449.9	527.6	894.3
10	49.0	87.0	150.8	204.7	244.9	393.3
20	30.4	50.5	82.2	105.5	127.9	196.1
30	20.1	31.6	48.8	59.8	73.1	107.7
40	14.0	21.0	31.0	36.6	44.9	63.9
50	10.2	14.7	20.8	23.9	29.4	40.5
60	7.7	10.7	14.7	16.5	20.2	27.2
70	6.0	8.1	10.9	12.0	14.6	19.2
80	4.8	6.4	8.4	9.1	11.1	14.3
90	4.0	5.2	6.6	7.2	8.7	11.1
100	3.3	4.3	5.5	6.0	7.1	8.9

ISO 15, 22, 32, 46 and 68 based on typical figures for the Esso Nuto range of HM oils. ISO 37 based on Shell Tellus HM oil.